

AGROBACTERIUM-MEDIATED TRANSFORMATION OF INDICA RICE CULTIVARS GROWN IN VIETNAM

TRAN THI CUC HOA, AMIRHUSIN BAHAGIAWATI¹, THOMAS K. HODGES¹

ABSTRACT

Genetic transformation of rice (Oryza sativa L.) mediated by Agrobacterium tumefaciens has been performed on 5 indica cultivars grown in Vietnam. Embryogenic calli derived from mature seeds were inoculated with A. tumefaciens LBA4044 in which the T-DNA contained plasmid pSBbarB-UbiCre or plasmid pSB35L-Hyg-L-Gus. Transformation efficiency recorded as the number of independent transgenic plants showing Southern blot⁺ per the number of embryogenic-derived calli ranged from 1.78-13.33%. Southern analyses of T0 independent transformants revealed that the transgene in most of transformants integrated into the genome as a single locus.

Key words: Rice, indica rice, *Agrobacterium*, transformation

INTRODUCTION

The advantage of genetic transformation of the rice plants using *Agrobacterium tumefaciens* has been widely cited in recent years (Hei et al. 1997; Komari et al. 1998) since the success of Hiei et al. (1994) in demonstrating that the rice plants could be transformed using *Agrobacterium tumefaciens* with an efficiency as high as in dicotyledonous plants. These authors transformed japonica varieties using *A. tumefaciens* strain LBA4404 containing the plasmid pTOK233 which had the *virB*, *virC* and *virG* genes of supervirulent pTiBo542 (Hood et al. 1986; Jin et al. 1987; Komari 1990) added to the binary vector. The efficiency of transformation was 20.5% of calli treated. Subsequently, Aldemita and Hodges (1996), Rashid et al. (1996), and Yokoi et al. (1997) followed the technique

demonstrated by Hiei et al. (1994) with some minor modifications to transform japonica and indica varieties. *Agrobacterium*-mediated transformation of javanica rice has also been shown (Dong et al. 1996).

In the present study, we demonstrated that *Agrobacterium* - mediated transformation methods could be applied to the indica varieties grown in Vietnam. This would help in improving the rice varieties of the country by gene transfer technology.

MATERIALS AND METHODS

Rice cultivars and culture media

Five indica rice cultivars: DS20, OMCS96, OMCS97, IR72 and IR64 were used for tissue culture and transformation experiments. Mature seeds were de-husked and then sterilized by treating with 70% ethanol for 2 min

¹ Department of Botany and Plant Pathology, Purdue University, West Lafayette, Indiana, U.S.A.

and then 70% (v/v) chlorox bleach (5.25% sodium hypochloride) for 30 min. The chlorox solution was removed and the seeds were treated with fresh 70% chlorox for a further 30 min and then rinsed thoroughly 3 times with sterile water. After sterilization, the seeds were cultured on callus induction medium MS (Table 1) and observed for callus growth weekly for 3 weeks. Calli were transferred to medium MS and embryogenic calli were selected, separated into small pieces (1-2mm) and precultured on medium MS for 4 days before transfer to co-cultivation medium MS.

***Agrobacterium tumefaciens* strain and plasmid**

The *A. tumefaciens* strain LBA4404 was obtained from Japan Tobacco Inc. (Hiei et al. 1994). Two plasmids were used separately:

(1) pSBbarB-UbiCre: the *barB* gene for phosphinothricin (ppt) resistance was driven by the 35S promoter of cauliflower mosaic virus plus Cre gene driven by the maize ubiquitin promoter plus (Fig. 1A);

(2) pSB35SL-Hyg-L-Gus: *hyg* gene was flanked by Lox sequences driven by 35S promoter cauliflower mosaic virus plus the *gusA* gene without

the promoter (Fig. 1B).

Transformation procedures

The transformation procedure used by Aldemita and Hodges (1996) for explant as immature embryo was basically followed with minor modifications for mature seeds used as explant in this study. Cultures of *A. tumefaciens* were prepared from glycerol stock and grown on AB medium (Chilton et al. 1974), a single colony of the *Agrobacterium* was transferred to 6 ml of YEP medium (An et al. 1988) containing 50 mg l⁻¹ Spectinomycin and grown for 28-30 hrs at 29°C. The culture was centrifuged at 2,800 rpm for 15 min and the pellet was resuspended in 10 ml of PIM2 medium plus 100 mM acetosyringone (AS), and incubated for 14-16 hrs at 29°C to a final A₆₀₀ of 1.6-1.9. AS was added to the bacterial suspension to give a final concentration 200 mM and immediately 10 µl of the bacterial suspension added to the embryogenic callus. Three days after co-cultivation (MSCo medium) with *A. tumefaciens*, the calli were transferred to medium MS containing carbenicillin 250 mg l⁻¹ and cefotaxime 100 mg l⁻¹ to inhibit the growth of *Agrobacterium*.

Fig. 1A

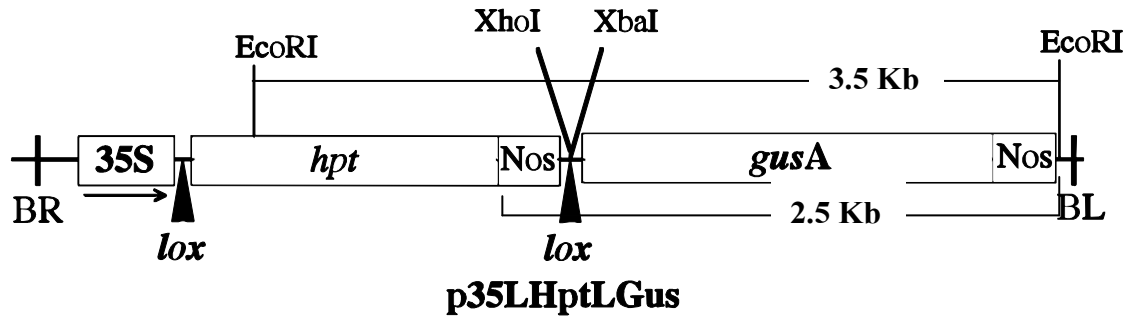

Fig. 1B

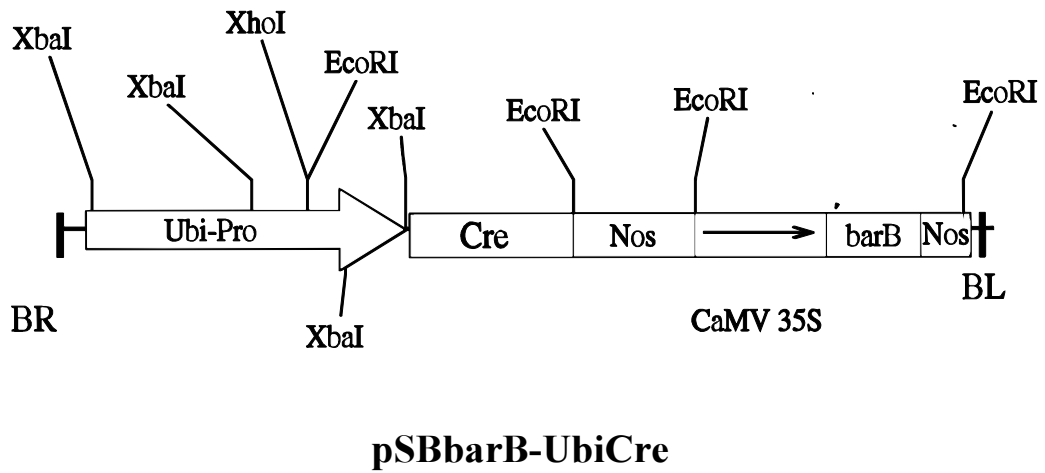

Fig 1. A schematic diagram of the plasmid (A) pSBbarB-UbiCre and (B) pSB35SL-Hyg-L-Gus

Table 1. Rice tissue culture and transformation media

Medium	Composition
AB	Chilton <i>et al.</i> (1974), 3g l ⁻¹ K ₂ HPO ₄ , 1g l ⁻¹ Na ₂ H ₂ PO ₄ , 1g l ⁻¹ NH ₄ Cl, 0.3g l ⁻¹ MgSO ₄ .7H ₂ O, 0.15 gl ⁻¹ KCl, 0.01 gl ⁻¹ CaCl ₂ , 0.0025 g l ⁻¹ FeSO ₄ .7H ₂ O, 5 g l ⁻¹ glucose, 15 g l ⁻¹ agar, pH 7.2
PIM2	1g l ⁻¹ NH ₄ Cl, 0.3g l ⁻¹ MgSO ₄ , 0.15 g l ⁻¹ KCl, 0.01 g l ⁻¹ CaCl ₂ , 0.0025 g l ⁻¹ FeSO ₄ , 10 g l ⁻¹ glucose, 14.64 gl ⁻¹ MES, 0.28 g l ⁻¹ Na ₂ HPO ₄ , 0.27 g l ⁻¹ NaH ₂ PO ₄ .H ₂ O, 20 mg l ⁻¹ acetosyringone, pH 5.6
MS	MS salts and vitamins (Murashige and Skoog. 1962), 30 g l ⁻¹ sucrose, 2mg l ⁻¹ 2,4-D, 1 g l ⁻¹ casein hydrolysate, 6 g l ⁻¹ agarose, pH 5.8
MSCo (co-cultivation)	MS salts and vitamins (Murashige and Skoog. 1962), 30 g l ⁻¹ sucrose, 2mg l ⁻¹ 2,4-D, 1 g l ⁻¹ casamino acids, 10 g l ⁻¹ glucose, 3g l ⁻¹ gelrite, 20 mg l ⁻¹ acetosyringone, pH 5.8
MSSe (selection)	MS salts and vitamins (Murashige and Skoog. 1962), 30 g l ⁻¹ sucrose, 2mg l ⁻¹ 2,4-D, 1g l ⁻¹ casamino acids , kinetin 0.001g l ⁻¹ , 3g l ⁻¹ gelrite, pH 5.8
MSRe (Regeneration)	MS salts and vitamins (Murashige and Skoog, 1962), 30 g l ⁻¹ sucrose, 50 mg l ⁻¹ tryptophan, 0.25 mg l ⁻¹ kinetin , 0.5 mg l ⁻¹ naphtheneacetic acid, 6 g l ⁻¹ agarose, pH 5.8
MSR (Rooting)	MS salts and vitamins (Murashige and Skoog, 1962), 30 g l ⁻¹ sucrose, 50 mg l ⁻¹ tryptophan, pH 5.8

Selection and regeneration of transformants

After three weeks, each callus was divided into small pieces (1-2 mm) and cultured on the medium MSSe with carbenicillin and cefotaxime supplemented with 50 mg l⁻¹ of hygromycin or 10 ppm of phosphinothricin (ppt) for a three-week period of selection. The resistant calli were separated into small pieces and

subjected to second selection on the same medium supplemented with 100 mg l⁻¹ of hygromycin or 10 ppm of ppt for a second 3-week selection period, putative transformed calli were transferred to the medium MS. Proliferated calli were then transferred to the medium MSRe and incubated at 25°C in the dark for one week before transferring to the growth chamber with 70% humidity, 25°C and 12-hr day length. Regenerated plantlets were

transferred to the rooting medium MSR, and after root development they were transferred to soil and grown in the greenhouse.

DNA isolation and Southern hybridization

Genomic DNA was isolated from leaf tissue of T0 plants following the method of McCouch et al. (1988). Southern blot analyses were performed according to Sambrook et al. (1989). Ten µg of genomic DNA digested with *Xba* I and *Eco*RI (double cut), or *Xho*I alone (single cut) were fractionated through 0.8% agarose gel by electrophoresis at 50 voltage for 12 hr, prior to capillary transfer to and immobilization on nylon membranes (Hybond-N⁺, Amersham).

RESULTS AND DISCUSSION

Two to three weeks after callus induction, approximately 50-90% of seeds cultured formed embryogenic callus on the medium MS. Six to 8 small pieces (1-2 mm) separated from the embryogenic callus of one mature seed were selected and placed on one petri plate and referred as one initiated mature embryo. They were co-cultivated with *A.*

tumefaciens LBA 4404 containing plasmid pSBbarB-UbiCre or plasmid pSB35SL-Hyg-L-Gus. Table 2 shows the effectiveness of *A. tumefaciens* LBA 4404 in transforming rice cultivars indica group. The transformation efficiency based on the number of independent transgenic plants showing Southern blot⁺ per the number of embryogenic-derived calli ranged from 1.78 to 13.33%. Rashid et al (1996) reported the frequency of transformation of Basmati 370 an indica variety was 22%. Aldemita and Hodges (1996) obtained a lower efficiency rate of 1-4% in transformation of two indica varieties. The results of our study confirmed the conditions for the success in rice transformation using *A. tumefaciens* (1) choice of the explant (in this case, embryogenic callus from mature seeds was found to be suitable for indica cultivars) (2) *A. tumefaciens* strain LBA4404 (3) maintenance of high concentrations of AS during co-cultivation of the calli with *Agrobacterium* and (4) appropriate selection procedures using hygromycin or ppt.

OMONRICE 7 (1999)

Table 2. Transformation efficiency of embryogenic calli derived from mature seeds of indica rice varieties (DS 20, OMCS 96, OMCS 97, IR 72 and IR64) infected with *Agrobacterium tumefaciens* LBA 4404 containing plasmid pSBbarB-UbiCre (BarB-UbiCre) or plasmid pSB35SL-Hyg-L-Gus (Hyg-Lox)

Variety	Experiment	Plasmid	Number of embryogenic-derived calli from mature seeds				Transformation efficiency (B/A, %)
			Inoculated (A)	Produced Hyg ^R or ppt ^R cells	Individual transform-ants recovered	South-ern blot ⁺ (B)	
DS20	1	Hyg-Lox	40	12	7	5	12.50
	2	Hyg-Lox	20	6	3	2	10.00
	3	Hyg-Lox	30	8	4	2	6.66
	4	Hyg-Lox	45	15	8	4	8.88
DS20	1	BarB-UbiCre	30	10	5	4	13.33
	2	BarB-UbiCre	9	3	2	1	11.11
	3	BarB-UbiCre	10	4	2	1	10.00
	4	BarB-UbiCre	40	10	4	3	7.5
OMCS 96	1	Hyg-Lox	27	5	3	2	7.4
	2	Hyg-Lox	34	7	3	2	5.88
	3	Hyg-Lox	50	21	7	4	8.00
OMCS 96	1	BarB-UbiCre	35	8	5	3	8.57
	2	BarB-UbiCre	14	3	2	1	7.14
	3	BarB-UbiCre	22	7	4	2	9.09
IR72	1	Hyg-Lox	15	2	1	1	6.66
	2	Hyg-Lox	10	4	2	1	10.00
	3	Hyg-Lox	40	11	4	3	7.50
	4	Hyg-Lox	25	10	3	2	8.00
IR72	1	BarB-UbiCre	16	3	2	1	6.25
	2	BarB-UbiCre	40	9	4	2	5.00
	3	BarB-UbiCre	41	10	5	3	7.31
	4	BarB-UbiCre	21	8	4	2	9.52
IR64	1	Hyg-Lox	18	8	2	1	5.55
	2	Hyg-Lox	42	6	3	2	4.76
	3	Hyg-Lox	48	15	5	4	8.33
IR64	1	BarB-UbiCre	34	7	1	1	2.94
	2	BarB-UbiCre	20	8	2	1	5.00
	3	BarB-UbiCre	25	10	4	2	8.00
OMCS97	1	Hyg-Lox	30	5	2	1	3.33
	2	Hyg-Lox	40	10	3	1	2.5
	3	Hyg-Lox	56	15	2	1	1.78
OMCS97	1	BarB-UbiCre	41	10	1	1	2.43
	2	BarB-UbiCre	50	15	2	1	2.00

In comparison with the efficiency in transformation of japonica varieties that we obtained from 14.28 to 32.43% (Taipei 309) and from 8.33-25.00% (Radon) (Tran and Hodges, 1999), the efficiency for indica varieties in this study was quite acceptable.

Southern blot analysis T0 plants using *gusA* probe and Cre probe revealed, in the case of double cut, the expected band of 2.11 kb and 1.05 kb respectively and

the bands in single cut showed simple integration of the transgene (Fig. 2 A-B). This indicated that in comparison of other methods of gene transfer in rice (Christou et al. 1991, Peng et al. 1992), *Agrobacterium* - mediated rice transformation gave rise to a so much fewer number of copies of genes integrated as well as the frequencies of gene rearrangement.

Fig. 2A

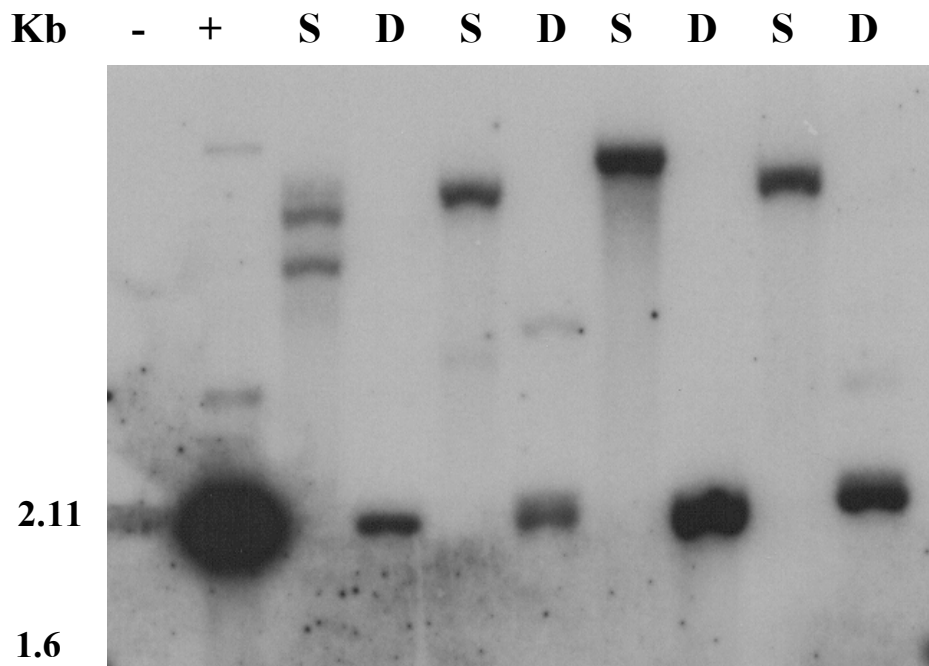

Fig. 2B

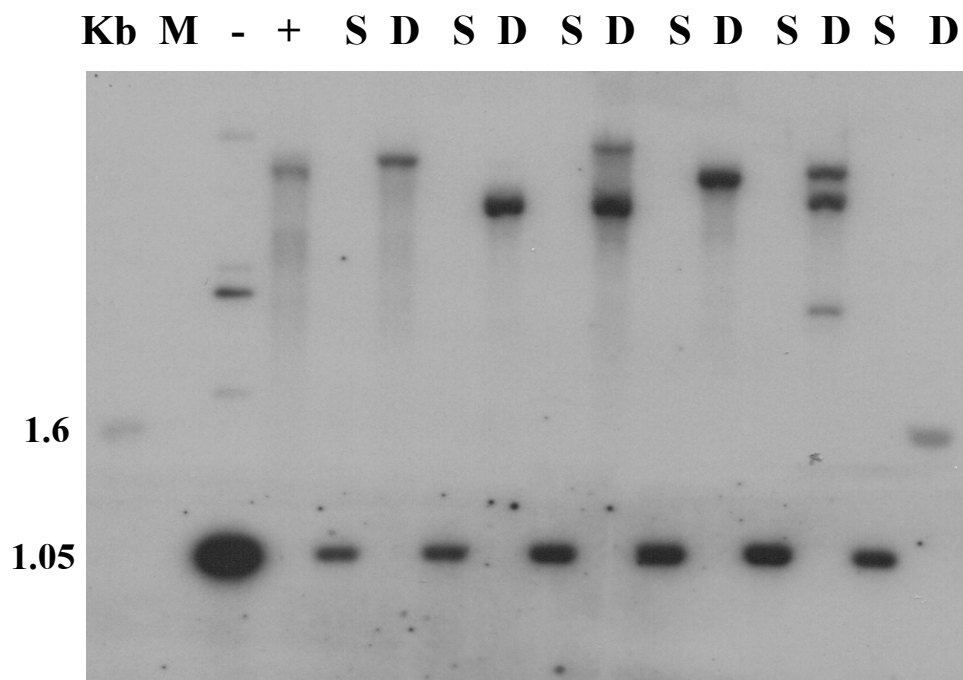

Fig 2. Southern analysis of T0 plants. DNA of these plants was digested with *Xho*I (single cut:S) and with *Eco*RI plus *Xba*I (double cut:D).

(A): OMCS96 using *gusA* probe, showing expected band at 2.11 kb in double cut

(B): DS20 using Cre probe, showing expected band at 1.05 kb in double cut

The bands in single cut showed simple integration of the transgene.

Acknowledgements

This study is a part of the postdoctoral research program granted to the first author by the Rockefeller Foundation.

References

An, G, Ebert PR, Mitra A, Ha SB 1988. Binary Vectors In: Gelvin SB, Schilperoot RA, Verma DPS

(eds) Plant molecular biology manual. Kluwer Academic Publishers, Dordrecht, pp: 1-19.

Aldemita RR, Hodges TK 1996. *Agrobacterium tumefaciens*-mediated transformation of japonica and indica rice varieties. Planta 199:612-617.

- Chilton MD, Currier TC, Farrand SK, Bendich AJ, Gordon MP, Nestor EW 1974. *Agrobacterium tumefaciens* DNA and PS8 bacteriophage DNA not detected in crown gall tumors. Proc Natl Acad Sci USA 71:3672-3676.
- Christou P, Ford TL, Kofron M 1991. Production of transgenic rice (*Oryza sativa* L.) plants from agronomically important indica and japonica varieties via electric discharge particle acceleration of exogenous DNA into immature zygotic embryos. Bio Technology 9: 957-962.
- Dong J, Teng W, Buchholz WC, Hall TC 1996. *Agrobacterium*-mediated transformation of javanica rice. Mol Breed 2:267-276.
- Hiei Y, Ohta S, Komari T, Kumashiro T 1994 Efficient transformation of rice (*Oryza sativa* L.) mediated by *Agrobacterium* and sequence analysis of the boundaries of the T-DNA. Plant J 6: 271-282.
- Hiei Y, Komari T, Kubo T 1997. Transformation of rice mediated by *Agrobacterium tumefaciens*. Plant Mol Biol 35:205-218.
- Hood EE, Fraley RT, Chilton MD 1986. The hypervirulence of *Agrobacterium tumefaciens* A281 is coded in a region of pTiBO542 outside the T-DNA. J Bacteriol 168:1291-1301.
- Jin S, Komari T, Gordon MP, Nester EW 1987. Genes responsible for the supervirulence phenotype of *Agrobacterium tumefaciens* A281. J Bacteriol 169:4417-4425.
- Komari T, Hiei Y, Ishida Y, Kumashiro T, Kubo T 1998. Advanced in cereal gene transfer. Curr Opin in Plant Biol 1:161-165.
- Komari T 1990. Transformation of cultured cells of *Chenopodium quinoa* by binary vectors that carry a fragment of DNA from the virulence region of pTiBo542 . Plant Cell Rep 9: 303-306.
- McCouch SR, Kochert G, Yu ZH, Wanh ZY, Khush GS, Coffman WR, Tanksley SD 1988. Molecular mapping of rice chromosomes Theor Appl Genet 78:815-829.
- Musharige T, skoog F 1962 A revised medium for rapid growth and bioassays with tobacco tissue culture. Physiol Plant 15: 473-497.
- Peng J, Wen F, Lister R, Hodges TK 1992. Inheritance of *gusA* and *neo* gene in transgenic rice. Plant Mol Biol 27:91-104.
- Tran Thi Cuc Hoa and T. K. Hodges. 1999. High efficiency of transformation of japonica and indica rice cultivars with *Agrobacterium tumefaciens* facilitates the study of gene excision from the rice genome by the *Cre/lox* site-specific recombination system (submission to Plant Cell Reporter).
- Rashid H, Yokoi S, Toriyama K, Kinata K 1996. Trasgenic plant

- production mediated by *Agrobacterium* in indica rice. Plant Cell Rep 15:727-730.
- Sambrook J, Fritsch EF, Maniatis T 1987. Molecular cloning: A laboratory manual, 2nd edn. Cold Spring Harbor Laboratory Press. Cold Spring, Harbor, NY.
- Yokoi S, Tsuchiia T, Toriyama K, Hanita K 1997. Tapetum-specific expression of the Osg6B promoter- β -glucuronidase gene in the transgenic rice. Plant Cell Rep 16: 363-367.

TÓM TẮT

Chuyển nạp gen bằng *Agrobacterium* cho một số giống lúa trồng ở Việt Nam

Phương pháp chuyển nạp gen bằng vi khuẩn *Agrobacterium tumefaciens* đã được áp dụng cho 5 giống lúa thuộc nhóm indica đang trồng ở Việt Nam: ĐS20, OMCS96, OMCS97, IR64 và IR72. Các mô sẹo tạo từ hạt già được chủng với dòng *A. tumefaciens* LBA4044 mang plasmid pSBbarB-UbiCre hoặc plasmid pSB35L-Hyg-L-Gus. Hiệu quả chuyển gen được tính bằng tỷ lệ số cây chuyển gen độc lập thu được thể hiện quan phân tích Southern trên số mô sẹo được chủng vi khuẩn. Hiệu quả này ở các giống lúa trên trong khoảng từ 1,78-13,33%. Kết quả phân tích Southern cho thấy ở hầu hết cây chuyển gen, gen được kết nạp vào nhiễm sắc thể ở một vị trí (locus).